

# ARRIEL 2E

FOR THE EC 145 T2

PROVEN DESIGN, LOW COST, RELIABLE & HIGH PERFORMING



Since 1978 Turbomeca (Safran group) has produced over 10,000 Arriel engines.

Between them they have accumulated more than 32 million flying hours, many while operating in extreme conditions.

Turbomeca invested the best of 30 years of knowledge and experience, into this new variant.

The new Arriel 2E delivers low cost, reliability and performance

#### > LOW Operating Costs

- 4,000 hour TBO at Entry-into-Service, with the targeted extension of 6,000 hours by implementation of our on-condition monitoring program.
- Reduced maintenance costs via our innovative new monitoring system.

#### > HIGH Reliability / Maintainability

- Proven technologies and extensive experience.
- **New generation dual-channel FADEC:**
  - Classic functions: automatic start protection and N1/N2 recording, automatic oil and fuel system monitoring.
  - HP blade creep-monitoring for additional savings.
- **Engine Data Recorder (EDR)**
  - FADEC memory dump for faster data transfer.
  - Capture and store data enabling preventive maintenance.
  - Link to Turbomeca diagnostic services via an interactive secure internet portal (coming soon).

#### > HIGH Performance

- Arriel 2E provides all the power, Captains need for demanding missions, especially during take-off and landing.
  - Class 1 performances are significantly enhanced with 30 sec & 2 min power ratings.
- The Arriel 2E offers a special 30 minutes power rating for occasional use.

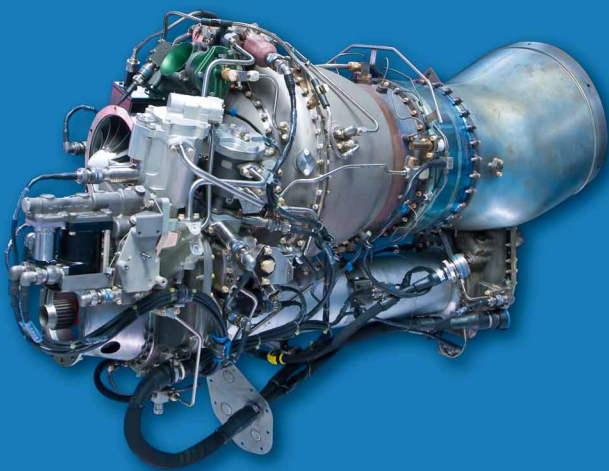

> Helicopters:



EC 145 T2  
powered by two Arriel 2E

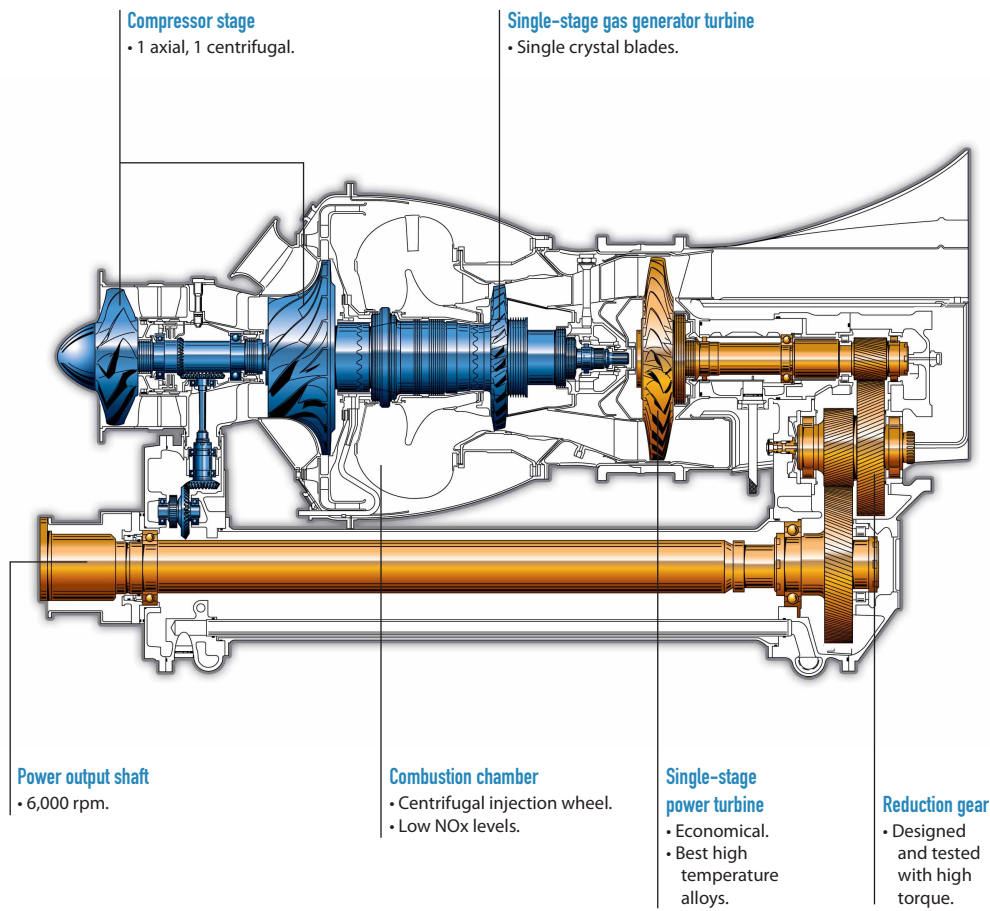

> Power rating (shp/kW):

	Arriel 2E
<b>&gt; One Engine Inoperative (OEI)</b>	
OEI 30 sec.	1072 / 800
OEI 2 min.	1039 / 775
OEI continuous	951 / 710
<b>&gt; All Engines Operative (AEO)</b>	
Take-off power	894 / 667
Max. continuous power	828 / 618

> Description:

- The Arriel 2E comprises five modules providing simplified maintenance at low cost. It is controlled by a new-generation **dual-channel FADEC**, a benchmark for efficient power control and fuel consumption. The **new design** of many of its components enhances its already high performance and ensures that the Arriel remains the most reliable engine in its class.
- The EDR, together with the blade-creep monitor, further shifts the emphasis from **traditional to pre-emptive maintenance**. These innovations also drastically reduce unscheduled removals and significantly improve helicopter availability.

Turbomeca is dedicated to the design, production, sale and support of gas turbines for helicopters. Turbomeca offers the world's most comprehensive range of engines, along with strong industrial cooperation associated to close-by customer services structures. Dedicated to 2,350 customers in 155 countries, Turbomeca provides a proximity service thanks to its 16 sites, 26 Maintenance Centers, 24 Repair & Overhaul Centers and 90 Field representatives and Field technicians.



This document is intended for general information purposes only. Turbomeca reserves the right to modify the products and services described in this document without prior notice.